

DH-PFM3640LS-D1B100

Integrated Solar System

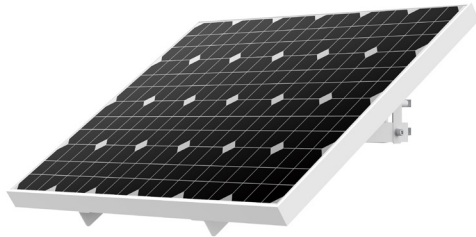

- The bracket is made of integrated galvanized steel, which is easy to install.
- IP66 rated.
- Self-heats when the battery temperature is 0 °C and stops at 5°C to ensure that it can work in low temperatures.
- Reads its battery power data.
- The indicator light shows the device status in real time.

System Overview

Dahua Integrated Solar Power Supply System reliably provides stable power to devices when there is no mains power supply available. It is easy to install and use, and is highly durable and reliable.

Technical Specification

System

Output Voltage	11.1 VDC (9 V–12.6 V)
Output Current	10 A
Power Consumption In Idle	<50 uA

Solar Panel

Type	Monocrystalline silicon
Max. Power	100 Wp
Efficiency	0.19

Battery

Type	Ternary lithium
Nominal Capacity (20°C/68°F, 5 h)	40 AH
Low Temperature Discharge Performance	≥70% nominal capacity (–20 °C [–4 °F], 5 hr)
Normal Temperature Discharge Performance	≥99% nominal capacity (25 °C [77 °F], 5hr)
High Temperature Discharge Performance	≥90% nominal capacity (55°C [131 °F], 5hr)
Upper Limit of Charging Voltage	12.6 VDC
Max. Charging Current	10 A
Charge and Discharge Cycle Times	>500 times

Protection

Over Discharge Protection Voltage	9 VDC
Low Temperature Charging Inhibition	0 °C (32 °F)
Low Temperature Discharging Inhibition	–20 °C (–4 °F)
Protection	IP66
Others	Protection against overheating overcharging, overloading and short circuits.

Port

Power Output Port	Φ 5.5 mm × Φ 2.1 mm × 12 mm (Φ 0.22" × Φ 0.08" × 0.47")
RS-485	1

Structure

Main Body Material	Photovoltaic panel frame: aluminum alloy Battery compartment: PC and ASA Bracket: Q235
Installation	Column-shaped vertical pole (Φ80 mm–180 mm)
Product Dimensions	765 mm × 674 mm × 417 mm (30.12" × 26.54" × 16.42")
Packaging Dimensions	825 mm × 690 mm × 100 mm (32.48" × 27.17" × 3.94")
Net Weight	12.5 kg (27.56 lb)
Gross Weight	14.9 kg (32.85 lb)

Environment

Operating Altitude	≤3,000 m (9,842.52 ft)
Applicable Area	The device needs to be exposed to direct sunlight for at least 3.5 hours under standard lighting intensity to ensure it operates normally.
Operating Temperature	Charging: –20 °C to +50 °C (–4 °F to +122 °F); the device self-heats when the battery reaches 0 °C Discharging: –20 °C to +55 °C (–4 °F to 131 °F)

Solar Power Supply System | DH-PFM3640LS-D1B100

Operating Humidity	10%–90% (RH)
Storage Temperature	–35 °C to +65 °C (–31 °F to +149 °F); the storage time is less than 3 months. –10 °C to +25 °C (+14 °F to +77 °F); the storage time is less than 12 months.
Storage Humidity	65 ± 20% (RH)
Anti-corrosion Level	Basic Protection
Certification	
Certifications	CE

Ordering Information

Type	Model	Description
Solar Power Supply System	DH-PFM3640LS-D1B100	Integrated Solar System

Dimensions (mm[inch])

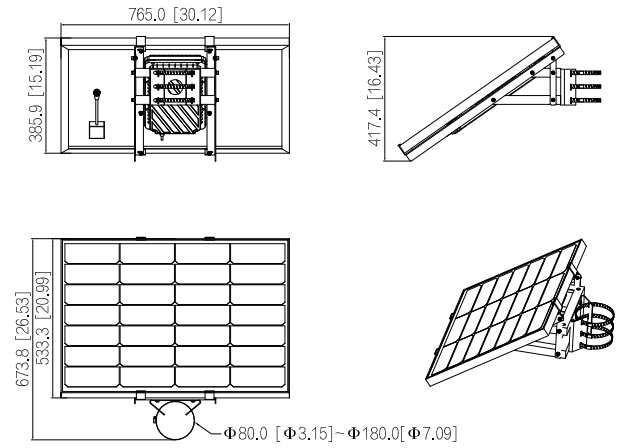

Application

