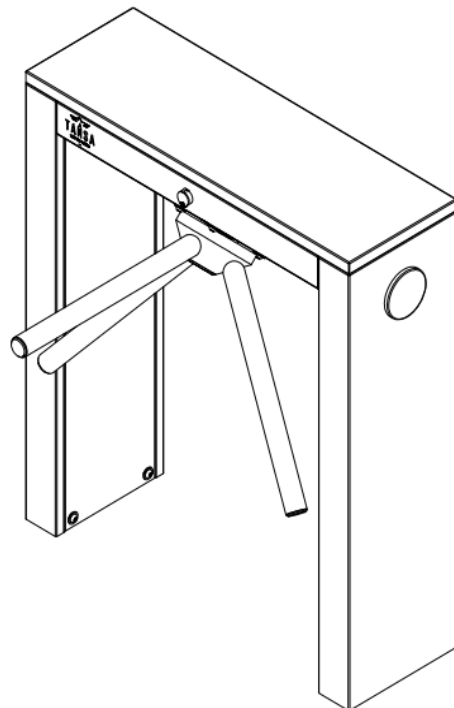




# TRIPOD TURNSTILE USER MANUAL





---

# CONTENTS

## Introduction

5

## Chapter 1: General Information

<i>1.1 General specifications</i> .....	6
<i>1.2 Tripod turnstile types</i> .....	7
<i>1.3 Package Contents</i> .....	8
<i>1.4 Hardware changes</i> .....	8
<i>1.5 Symbols and definitions</i> .....	8

## Chapter 2: Technical information

<i>2.1 Technical Specifications</i> .....	9
<i>2.2 Technical specifications table</i> .....	10
<i>2.3 Optional accessories</i> .....	11

## Chapter 3: Installation and Assembly

<i>3.1 Required tools</i> .....	12
<i>3.2 Field preparation</i> .....	13
<i>3.2.1 Floor Mounting</i> .....	14
<i>3.2.2 Cabling</i> .....	15
<i>3.3 Turnstile hub assembly</i> .....	16
<i>3.4 Turnstile arm assembly</i> .....	17
<i>3.4.1 Drop arm assembly</i> .....	17
<i>3.4.2 Normal arm assembly</i> .....	17

## Chapter 4: Turnstile mechanism information

<i>4.1 Internal parts</i> .....	18
<i>4.2 How to open the cover</i> .....	19
<i>4.3 Turnstile mechanism</i> .....	20
<i>4.3.1 Shock absorber adjustment</i> .....	21

4.4 Guiding indicators.....	22
4.5 Supply unit and grounding.....	23

## **Chapter 5: Electrical Connections**

5.1 Control card and specifications.....	24
5.2 TEC-101 control card.....	27
5.3 Control card key descriptions.....	28
5.4 Control card terminal descriptions (XL5)	30
5.4.1 External connection types.....	31
5.4.1.1 Triggering with dry contact.....	31
5.4.1.2 Triggering with energy input.....	31
5.4.2 Alarm cable group turnstile connection.....	32
5.5 Control card terminal descriptions (XL9).....	33
5.5.1 How to use pass relays.....	34
5.5.2 Pass relays and counter connection	34

## **Chapter 6: Product Usage Instructions**

6.1 Safety and Operating Instructions.....	35
6.2 Maintenance Instructions.....	36

## **Chapter 7: Fault Condition**

7.1 Troubleshooting.....	37
--------------------------	----

## **Chapter 8: Warranties**

8.1 Warranty conditions.....	40
8.2 Out of warranty conditions.....	41
8.3 Warranty certificate.....	42

## **Chapter 9: Quality certificates**

9.1 Management system certificate and attachment.....	43
9.2 CE certificate and TSE certificate.....	44

# INTRODUCTION

*Dear valued customer,*

*Thank you for choosing our tripod turnstile. We want to offer you the best efficiency. Please read this manual carefully. This manual contains detailed information on the installation and maintenance of turnstiles. The information contained in this manual is of great importance in order to extend the service life of the turnstile and to obtain maximum efficiency.*

Turnstiles have an active place in our daily lives and are used in many areas. It is possible to see them in several places such as public transportation stations, business and training centers, parks, dining halls, stadiums, prisons, etc.

The nature and purpose of the areas where turnstiles are used is the biggest factor in the design and production of turnstile models. Our products, which are created by taking this factor into consideration, are grouped into four main categories: Tripod turnstiles (waist high turnstiles), Swing gate turnstiles (handicapped accessible turnstiles), Full-height turnstiles, and Speed gate turnstiles. In addition, Full-height turnstiles and the Speed gate turnstiles also have handicapped accessible versions.

Turnstiles can be produced as stainless steel, galvanized or electrostatic powder-coated according to customer demands. Optionally, different solutions are available for some product models.

Turnstiles are compatible with any kind of magnetic, biometric, proximity and similar readers. In addition, applications such as buttons, coins, remote controls can be integrated and used with a turnstile.

All materials used in the turnstiles are designed to be water and dust resistant and tested in accordance with IP44 standards. Mechanical parts of the turnstiles are protected against corrosion and oxidation with AISI 304 stainless steel and zinc plating.

Turnstiles can work in both directions. The anticipated use per hour is at the level of 1500 persons.

All TANSA brand turnstiles have certificates of compliance with TSE, ISO 9001 and CE standards.

## HEADQUARTER:

**Address:** Eyüp Sultan Mahallesi. Hoca Nasreddin Caddesi. No: 10  
Sancaktepe / İSTANBUL

**Phone:** +90 (216) 561 96 71-72-73

**Fax:** +90 (216) 561 96 74-75

**E-mail:** [info@tansa.com.tr](mailto:info@tansa.com.tr)

# 1

## GENERAL INFORMATION

### 1.1 General specifications

**Working Direction:** Turnstiles can work in both directions regardless of model and category. They can be used as entry and exit.

**Movement and Drive:** Arms of the tripod turnstile move manually. There is no need to touch the arms of the turnstile with hands. The arm rotates easily with body contact.

**Case / Frame Material:** Tripod turnstile can be made of 1.2mm in standard, or 1.5 mm or 2mm based on order, AISI 304 quality stainless steel or of 1.5 mm DKP sheet as electrostatic powder-coated.

**Rotor, Arm and Wing Parts:** In the waist high turnstiles, arms are threaded joint mounted and made of polishing covered hard aluminum. In drop arm turnstiles, arms are designed as screw-mounted. Arms can also be manufactured as stainless steel.

**Turnstile Functions:** Electronic microprocessor control allows passage in both directions, and provides usage information. Users are guided by the indicators on the turnstile. The contact, opening and automatic closing times of the turnstile can be set on the electronic control panel. The memory mode allows faster passage. The turnstile can be operated on locked to the desired direction mode or free mode while in standby. Optionally, a passage indicator can be added on the cover.

## 1.2 Tripod turnstile types



**LTT 303:**  
Normal case  
double leg tripod  
turnstile



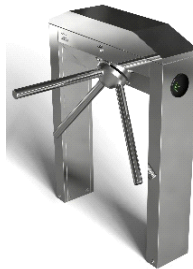
**LTT 303S:**  
Narrow case  
double leg tripod  
turnstile



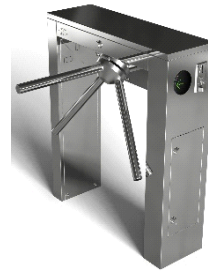
**LTT 303E:**  
Special cover  
cylindrical  
double leg tripod  
turnstile



**LTT 303A:**  
Angle Cover  
Double Leg  
Tripod Turnstile



**LTT 303AS:**  
Narrow case,  
angle cover  
double leg tripod  
turnstile



**LTT 303J:**  
Coin operated  
double leg tripod  
turnstile



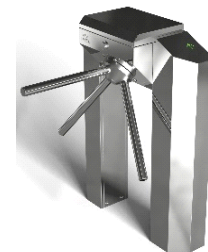
**LTT 313E:**  
Single-wide leg  
tripod turnstile



**LTT 313:**  
Single-narrow leg  
tripod turnstile



**LTT 313EJ:**  
Coin operated  
single-wide leg  
tripod turnstile



**LTT 323:**  
Wide case  
tripod turnstile



LTT 303/ LTT 303A/ LTT 313/ LTT 313E/ LTT 323 turnstiles models have double versions.

## 1.3 Package Contents

Package contents may vary according to the turnstile models. Make sure that the package contents below are complete. If you find any deficiency or fault, please contact TANSA.

A standard turnstile package should include:

- 1 pcs LTT 3XX Turnstile
- 3 turnstile arms (6 turnstile arms on double turnstile models)
- 1 pcs cover opening key
- 1 pcs shock absorber hex key
- Stud and nut for fixing
- User manual

## 1.4 Hardware changes

As the IP44 protection of the turnstile becomes invalid in any change made on the turnstile, any mechanical or electrical change shall not be made without the permission of TANSA, and TANSA shall not be liable for any problems that may arise otherwise. The intended change must be notified in writing to TANSA in advance. Additional technical information, warnings and precautions may be provided by TANSA if necessary.

## 1.5 Symbols and definitions

The symbols and descriptions in the user manual are shown below.



**Important information and useful tips on using the turnstile.**



***Warning against dangerous situations in terms of life and property.***



# 2

## TECHNICAL INFORMATION

### 2.1 Technical specifications

**Mechanism Specifications:** The mechanism is made of hardened aluminum casting, the cams and locking tabs on the mechanism are made of AISI 304 stainless steel.

**Power Source:** All the turnstiles can work with 110/220 VAC. The operating frequencies of the turnstiles are 50 / 60 Hz.

**Internal Voltage:** There is no high voltage in any components except the supply unit in the turnstile. Depending on the turnstile model, 24/12 VDC internal voltage is measured.

**Power Failure and Emergency Mode:** All tripod turnstile models have emergency mode and are compatible with all types of fire / alarm panels. As soon as the emergency switch is on, the turnstile guiding indicators blink in the shape of green arrow and give sound warning, the arms are released in the unlocked position (LTT-3xx-DA) allowing free access. In the case of power failure in tripod turnstiles, arms run idle or drops in the drop-arm models allowing free access. In drop-arm models, arm should be lifted to the locked position by hand when the power is back.

**Operating Temperature:** Turnstiles can work smoothly in the temperature range between -10 and +70 degrees. It is recommended to use a thermostat heater, optionally, at temperatures lower than -10 degrees.

**Transport and Storage Temperature:** -20 to +80 degrees.

**Relative Humidity Ratio:** Maximum 95%.

## 2.2 Technical specifications table

Model	Height	Length	Width	Weight	Power consumption	Operating temperature
LTT - 303	980 mm	840 mm	280 mm	~35 kg	Max. 4.1 W	-10° to +70°
LTT - 303D	980 mm	840 mm	500 mm	~55 kg	Max. 8.2 W	-10° to +70°
LTT - 303A	1045 mm	840 mm	280 mm	~35 kg	Max. 4.1 W	-10° to +70°
LTT - 303AD	1045 mm	840 mm	500 mm	~55 kg	Max. 8.2 W	-10° to +70°
LTT - 303S	980 mm	840 mm	200 mm	~30 kg	Max. 4.1 W	-10° to +70°
LTT - 303AS	1045 mm	840 mm	200 mm	~30 kg	Max. 4.1 W	-10° to +70°
LTT - 303E	1000 mm	1000 mm	280 mm	~45 kg	Max. 4.1 W	-10° to +70°
LTT - 303J	980 mm	880 mm	280 mm	~40 kg	Max. 5.1 W	-10° to +70°
LTT - 313	1020 mm	450 mm	300 mm	~25 kg	Max. 4.1 W	-10° to +70°
LTT - 313D	1020 mm	450 mm	500 mm	~40 kg	Max. 8.2 W	-10° to +70°
LTT - 313E	1020 mm	450 mm	300 mm	~30 kg	Max. 4.1 W	-10° to +70°
LTT - 313ED	1020 mm	450 mm	500 mm	~45 kg	Max. 8.2 W	-10° to +70°
LTT - 313EJ	1020 mm	450 mm	300 mm	~25 kg	Max. 5.1 W	-10° to +70°
LTT - 323	1030 mm	800 mm	300 mm	~30 kg	Max. 4.1 W	-10° to +70°
LTT - 323D	1030 mm	800 mm	525 mm	~55 kg	Max. 8.2 W	-10° to +70°



The power consumption in the table indicates the power used by the turnstile at idle. The power consumption is reduced by 10% during operation.

## 2.3 Optional accessories

Model	LED *	Button Box	Card reader device	Coin Unit	Drop arm	Counter	Heater	Illegal pass alarm	Top cover pass LED
LTT - 303	<input checked="" type="checkbox"/>	<input type="checkbox"/>	<input type="checkbox"/>	<input checked="" type="checkbox"/>	<input type="checkbox"/>	<input type="checkbox"/>	<input type="checkbox"/>	<input type="checkbox"/>	<input type="checkbox"/>
LTT - 303D	<input checked="" type="checkbox"/>	<input type="checkbox"/>	<input type="checkbox"/>	<input checked="" type="checkbox"/>	<input type="checkbox"/>	<input type="checkbox"/>	<input type="checkbox"/>	<input type="checkbox"/>	<input type="checkbox"/>
LTT - 303A	<input checked="" type="checkbox"/>	<input type="checkbox"/>	<input type="checkbox"/>	<input checked="" type="checkbox"/>	<input type="checkbox"/>	<input type="checkbox"/>	<input type="checkbox"/>	<input type="checkbox"/>	<input type="checkbox"/>
LTT - 303AD	<input checked="" type="checkbox"/>	<input type="checkbox"/>	<input type="checkbox"/>	<input checked="" type="checkbox"/>	<input type="checkbox"/>	<input type="checkbox"/>	<input type="checkbox"/>	<input type="checkbox"/>	<input type="checkbox"/>
LTT - 303S	<input checked="" type="checkbox"/>	<input type="checkbox"/>	<input type="checkbox"/>	<input checked="" type="checkbox"/>	<input checked="" type="checkbox"/>	<input type="checkbox"/>	<input type="checkbox"/>	<input type="checkbox"/>	<input checked="" type="checkbox"/>
LTT - 303AS	<input checked="" type="checkbox"/>	<input type="checkbox"/>	<input type="checkbox"/>	<input checked="" type="checkbox"/>	<input checked="" type="checkbox"/>	<input type="checkbox"/>	<input type="checkbox"/>	<input type="checkbox"/>	<input checked="" type="checkbox"/>
LTT - 303E	<input checked="" type="checkbox"/>	<input type="checkbox"/>	<input type="checkbox"/>	<input checked="" type="checkbox"/>	<input type="checkbox"/>	<input type="checkbox"/>	<input type="checkbox"/>	<input checked="" type="checkbox"/>	<input checked="" type="checkbox"/>
LTT - 303J	<input checked="" type="checkbox"/>	<input type="checkbox"/>	<input type="checkbox"/>	<input checked="" type="checkbox"/>	<input type="checkbox"/>	<input type="checkbox"/>	<input type="checkbox"/>	<input type="checkbox"/>	<input type="checkbox"/>
LTT - 313	<input checked="" type="checkbox"/>	<input type="checkbox"/>	<input type="checkbox"/>	<input checked="" type="checkbox"/>	<input type="checkbox"/>	<input type="checkbox"/>	<input checked="" type="checkbox"/>	<input checked="" type="checkbox"/>	<input type="checkbox"/>
LTT - 313D	<input checked="" type="checkbox"/>	<input type="checkbox"/>	<input type="checkbox"/>	<input checked="" type="checkbox"/>	<input type="checkbox"/>	<input type="checkbox"/>	<input checked="" type="checkbox"/>	<input checked="" type="checkbox"/>	<input type="checkbox"/>
LTT - 313E	<input checked="" type="checkbox"/>	<input type="checkbox"/>	<input type="checkbox"/>	<input checked="" type="checkbox"/>	<input type="checkbox"/>	<input type="checkbox"/>	<input checked="" type="checkbox"/>	<input checked="" type="checkbox"/>	<input type="checkbox"/>
LTT - 313ED	<input checked="" type="checkbox"/>	<input type="checkbox"/>	<input type="checkbox"/>	<input checked="" type="checkbox"/>	<input type="checkbox"/>	<input type="checkbox"/>	<input checked="" type="checkbox"/>	<input checked="" type="checkbox"/>	<input type="checkbox"/>
LTT - 313EJ	<input checked="" type="checkbox"/>	<input type="checkbox"/>	<input type="checkbox"/>	<input checked="" type="checkbox"/>	<input type="checkbox"/>	<input type="checkbox"/>	<input checked="" type="checkbox"/>	<input checked="" type="checkbox"/>	<input type="checkbox"/>
LTT - 323	<input checked="" type="checkbox"/>	<input type="checkbox"/>	<input type="checkbox"/>	<input checked="" type="checkbox"/>	<input type="checkbox"/>	<input type="checkbox"/>	<input type="checkbox"/>	<input type="checkbox"/>	<input type="checkbox"/>
LTT - 323D	<input checked="" type="checkbox"/>	<input type="checkbox"/>	<input type="checkbox"/>	<input checked="" type="checkbox"/>	<input type="checkbox"/>	<input type="checkbox"/>	<input checked="" type="checkbox"/>	<input type="checkbox"/>	<input type="checkbox"/>

\*Guiding indicator

Descriptions of the signs in the table:



: Standard in the turnstile model.

: Can be added optionally to the turnstile model.

: Not applicable for the turnstile model.

# 3

## INSTALLATION AND ASSEMBLY

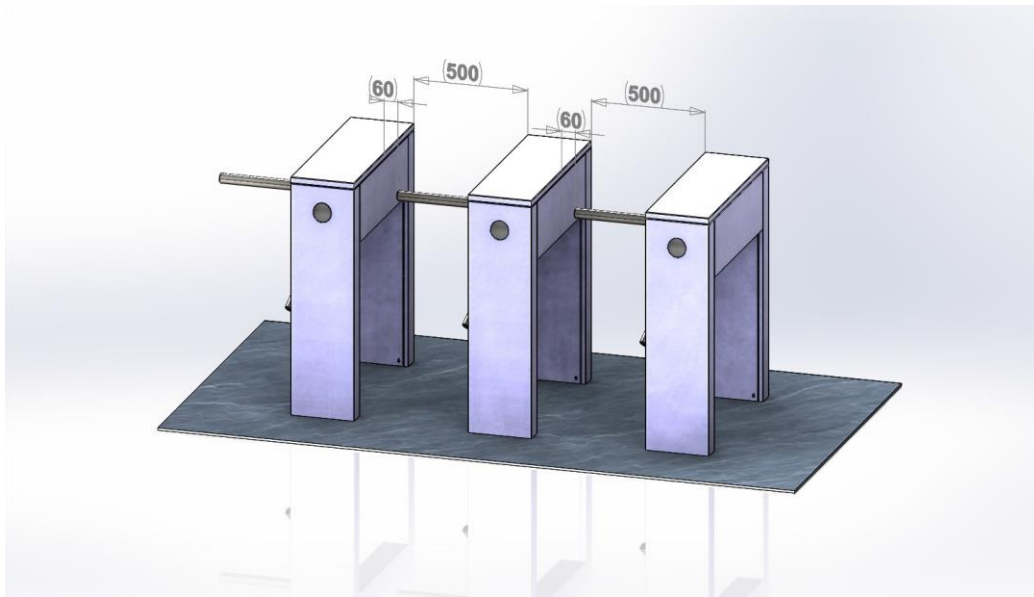
### 3.1 Required tools

The tools required for the installation of the turnstile are listed below.

 Meter	 Chemical adhesive	 10/12 mm drill bit
 Hammer drill	 5mm hex	 Spirit level
 Crimper	 Torque	 Phillips head screwdriver
 Socket wrench	 17/13 mm socket	 Flathead screwdriver

## 3.2 Field preparation

Turnstile dimensions differ according to the selected turnstile. It can be placed in the specified area in desired way and position. Figure 3.1 shows a section of LTT 303's layout.



*Figure 3.1 Turnstile layout*

There are some instructions to place the turnstiles.

### **Instructions:**

- The floor where the turnstiles are to be mounted must be completely flat and balanced. Installation should not be done if there is any bumps and slopes on the floor.
- Under the floor, which the turnstile is to be mounted, must not be empty. No mounting should be done on non-durable floors such as plasterboard, gypsum, sand etc.
- There should be no installation or cable under the floor where the turnstile is to be mounted. If necessary, it should be specified as a plan or project and mounted according to this information.
- No dust should be left in the holes while mounting of the turnstile on the floor. If possible, please remove the dust with a pneumatic hose or similar tools.
- Chemical mixture epoxy should be used while mounting the turnstile on ground and no work should be done before the freezing time (30 min) is completed.
- Mounting rods of 10 mm thickness and 150 mm length must be used to mount turnstiles on the floor.
- Before starting the installation of the turnstile, make sure that the conditions described in the "installation and assembly" chapter are present.

### 3.2.1 Floor mounting

After placement and positioning, the floor mounting of the turnstiles should be carried out according to the information given. Mounting brackets of the turnstile may vary by model and category. Mark the leg parts of the turnstiles by drawing around the area where it touches the floor. (Figure 3.2) Remove the mounting brackets screwed on the turnstile feet or body by using an M6 hex key. (Figure 3.3)

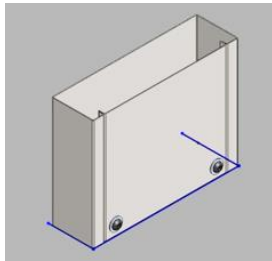


Figure 3.2

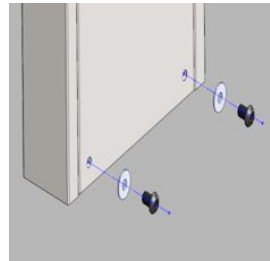


Figure 3.3

Place the mounting bracket on the floor 2mm inside by leaving equal space on the right and the left, then mark the mounting points on the floor (Figure 3.4). After marking all the brackets in this way, connected them firmly to the floor by screwing in the holes (Figure 3.5).



While screwing, pay attention to the position of the bracket that must have equal space on the right and left.

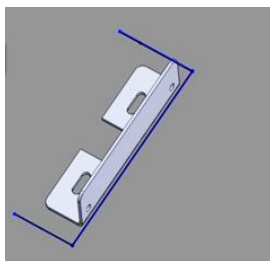


Figure 3.4

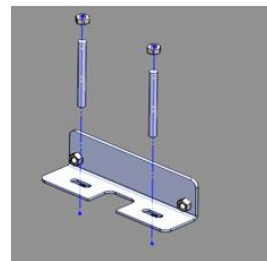
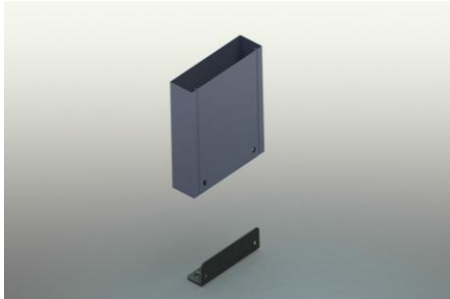


Figure 3.5

Place the power cable and control cables through the turnstile in a way to leave the brackets inside the turnstile. Tighten the previously unscrewed M6 hex keys. You have now completed the mechanical installation of turnstiles. (Figure 3.6 and Figure 3.7) The next step is connecting the power cable and control cables.



*Figure 3.6*



*Figure 3.7*

### 3.2.2 Cabling

Use a 3x1.5mm TTR power cable and 6A fuse for the turnstile supply. Grounding must be at least 25 amperes. A separate cable line must be installed for data and fire contact cables to card readers or other turnstile control devices to be connected to the turnstile. Data and fire cables must be installed in the same with electric cables.



**In places where a large number of turnstiles are installed side by side, emergency cables must be installed from one turnstile to the other. This parallel connection must be made in accordance with the emergency connection diagram.**

### 3.3 Turnstile hub assembly



*There should be no power in the turnstile during the assembly process.*



*Figure 3.8 Hub assembly*

The image shows the LTT 303 model turnstile, but all of our tripod turnstile hubs are assembled in the same way. Turnstiles are delivered from our factory as assembled. The turnstile hub consists of 6 parts in total. (*Figure 3.8*) Assembling and disassembling are very easy. Follow the steps for assembly:

Screw the screw (no. 1) and the screwing disc (no. 2) into the mechanism through the wedge hole in the mechanism. When this screw is tightened, there should be no power in the turnstile, and it must be locked in both directions as the mechanism will rotate from the inside. When there is no power, the locking tabs can also be held by hand.

Place any of the holes in the arm hub (no. 3) so as to pass through the screwing disc. Please note that the arm hole on the hub should face upwards. Pull the correctly placed hub from screws (no. 5) and washer group (no. 4), and firmly screw it to the screwing disk. The connection of the hub to the mechanism is completed, and the process over after placing the hub stopper (no. 6).

Disassemble: Follow the assembling order in reverse.



## 3.4 Tripod turnstile arm assembly

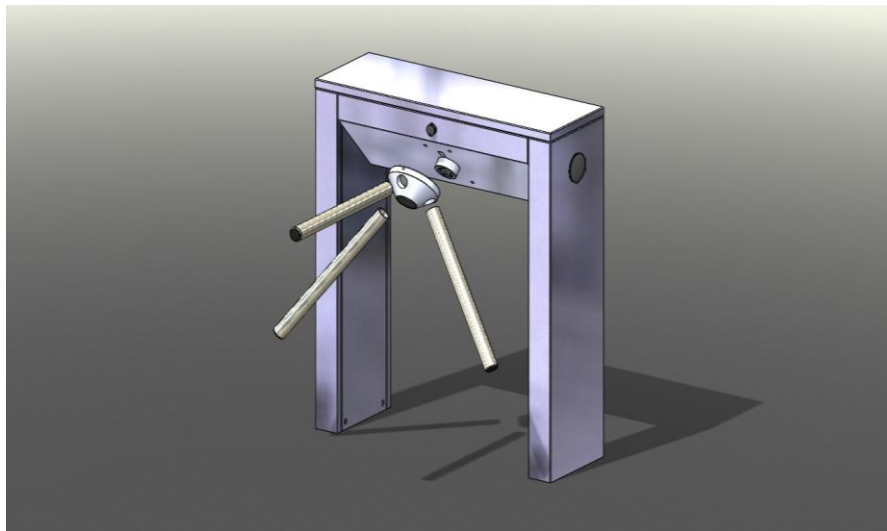
### 3.4.1 Drop arm assembly

Drop arms are produced as 40.5 cm in height with an aluminum hub as standard. Stainless steel arms can be used upon request. There is no difference between aluminum and stainless steel arms. Arms and hubs are delivered as assembled to the turnstile. If the arms need to be replaced, they should be disassembled and assembled in the following order.

1. The arms are connected to the hub joint by M4 screw, remove this screw.
2. After removing the screw, pull out the arm.
3. Place the new arm and screw firmly.

### 3.4.2 Normal arm assembly

After the hub is assembled, place the arms are placed into holes by rotating. (*Figure 3.9*)



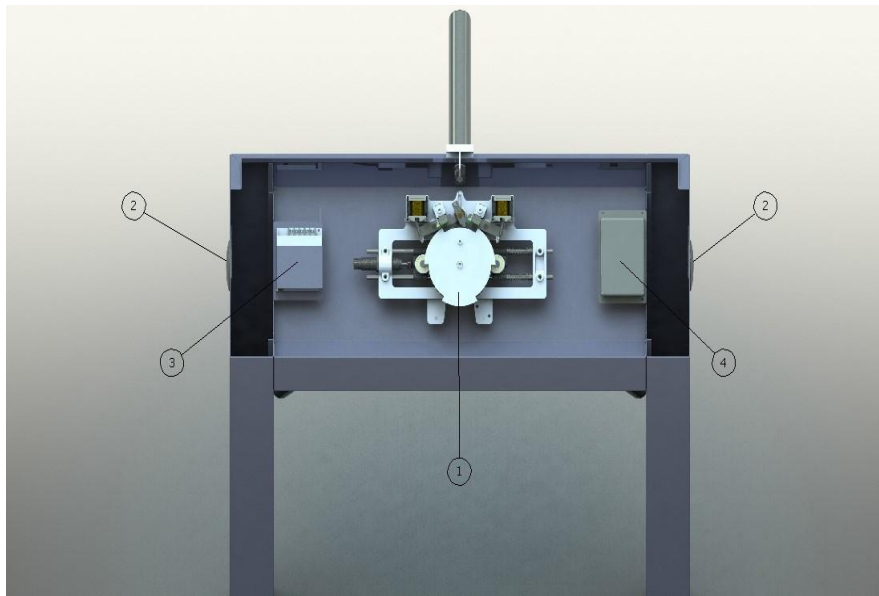
*Figure 3.9 Arm assembly*

# 4

## TURNSTILE MECHANISM INFORMATION

### 4.1 Internal parts

Open the turnstile cover, to see the internal mechanism shown in Figure 4.1. There is a main board, power supply and main mechanism in the turnstile mounted on the main body. Guiding indicators and LED plexis are mounted on the inside of the turnstile legs with rivets.



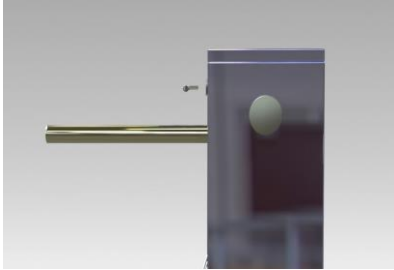
*Figure 4.1 Turnstile internal mechanism*

1. Main mechanism
2. A- B direction pass indicator
3. Power supply
4. Main board

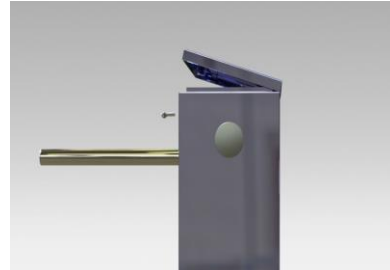


**The figure shows the internal parts of the single tripod turnstile. There are two pass indicators, power supplies and motherboards in the double tripod turnstile mechanism.**

## 4.2 How to open the cover

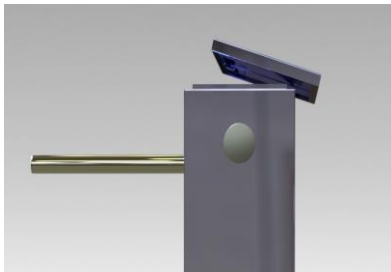


*Figure 4.2*

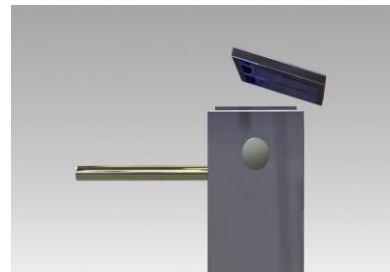


*Figure 4.3*

To access the interior parts of the turnstile, turn the top cover lock by turning it counterclockwise using the key provided with your turnstile as shown in the figures above. (*Figure 4.2 and Figure 4.3*)



*Figure 4.4*



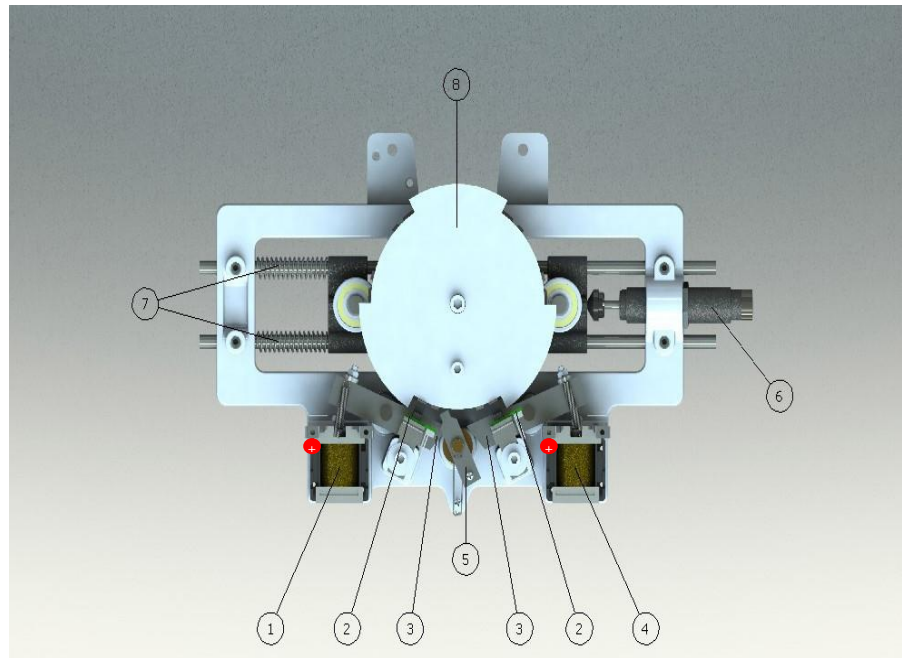
*Figure 4.5*

After unlocking, push the top cover of the turnstile back by gently lifting and remove it. (*Figure 4.4 and Figure 4.5*)



**It does not matter whether the turntable has an angle cover or a flat cover. Both are opened as described above.**

## 4.3 Turnstile mechanism



*Figure 4.6 Turnstile main mechanism*

**1- “A” directional solenoid:** Allows the arm to turn and stop by moving the locking tab. The operating voltage of the solenoids is 24VDC and they have +/- poles. In reverse connection the solenoid does not know even if there is energy. In Figure 4.6, (+) poles of the solenoids are indicated. The red solenoid cable should be connected to the (+) pole.



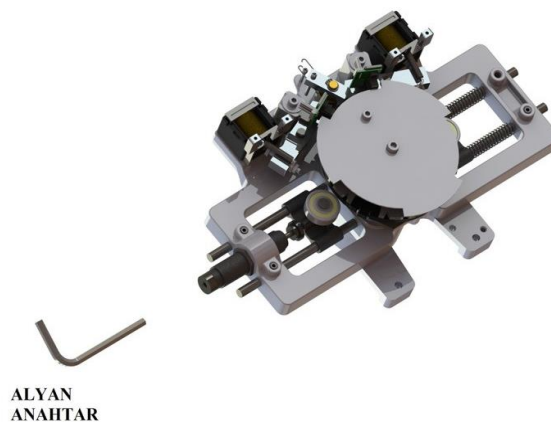
*Pay utmost attention while installing or removing the cable connection terminals during solenoid replacement or checks. Hold the terminal by hand from the bottom when loosening and tightening the terminal screws. The terminal leg may break in case of careless operation and stress.*

**2- Tour detector optical sensors:** Detect the start and end of the arm rotation. Provide pass information. Remove and clean inside with a brush and damp cloth for maintenance. Do not use alcohol or any contact spray. It is easy to disassemble / assemble thanks to the socket and locked connectors. To remove the socket, it is sufficient to unlock and pull out.

**3- Locking tab:** Blocks the gears of the mechanism with solenoid movement for locking.

- 4- **Reverse direction blocking tab:** Activated 30 degrees after the start of the tour to prevent the arm to rotate back.
- 5- **Shock absorber:** Absorbs and stops the impact during centering of the arm.
- 6- **Balance springs:** Supports the movement of the slide assembly on the cam.
- 7- **Tour disc:** Enables the tour to be detected by passing through the sensors during the rotation of the arm.

### 4.3.1 Shock absorber adjustment



*Figure 4.7 Shock absorber and hex key*

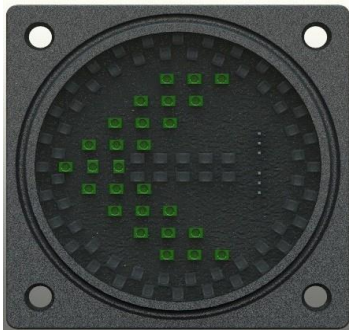
The shock absorber adjustment was made at the factory at room temperature and tested before delivery. If the temperature of the environment is less than 10 degrees or more than 35 degrees, it should be readjusted according to temperature conditions.

To adjust the shock absorber, follow the instructions below;

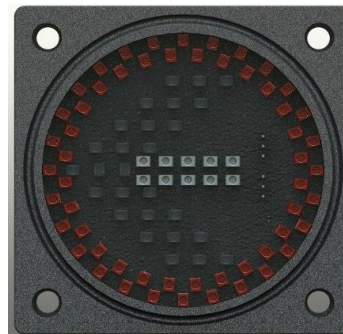
1. Loosen the allen bolt on the back of the shock absorber with a 1.5 mm hex key delivered in the turnstile. 1 or 1.5 turn would be enough for loosening. Do not completely remove the allen bolt when loosening. The shock absorber can not be adjusted as it can not be reassembled again when dislocated.
2. There are numbers from 0 to 9 on the back side. Turn towards zero to soften the shock absorber, and towards "9" to harden it.
3. When you find the right setting, screw the loosened allen bolt to complete the process.

## 4.4 Guiding indicators

Audio and visual warnings to guide user while passing and waiting are included in the turnstile equipment as standard. Audio warnings are given by the buzzer on the turnstile control card. Visual warnings are given by the guiding indicators shown below. Direction indicators can indicate various situations according to the type and duration of light.



*Figure 4.8*



*Figure 4.9*

The guiding indicator is shown separately for both directions. As shown in Figure 4.8, "Green arrow" indicates that the turnstile is in the free or controlled pass mode.

As shown in Figure 4.9, "Red no-entry sign" indicates that the turnstile closed to controlled or uncontrolled passing.

When the turnstile receives an entry/exit signal, the "Green arrow" on the guiding indicator disappears, and it shows "Red no-entry" sign.

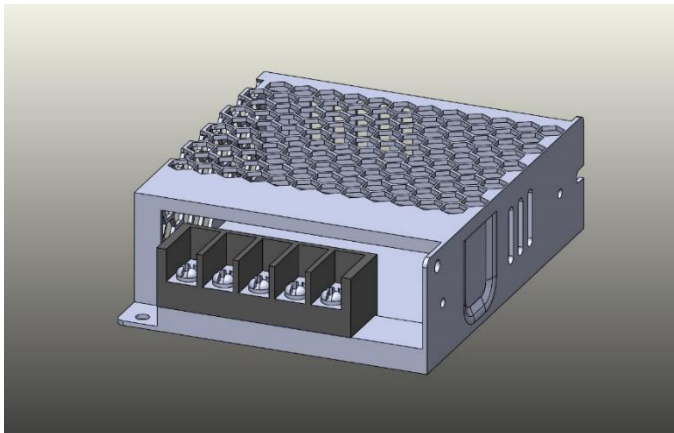
If desired, the position of sw7 on the function switches on the control card can be changed to reverse the guiding indicators. The operating mode described above is the standard factory setting. When SW7 is turned on, turnstile guiding LEDs will show "Red no-entry" sign on both sides while waiting, and the "green arrow" will appear when passing is allowed to the desired direction. The free passing direction will always remain "Green Arrow". When the free passing mode to one side is active, the "Green arrow" will be shown in the controlled passing direction and the "Red no-entry" sign will be shown in the opposite direction as the turnstile is busy. After passing, it will return to its original position.



When the power reach the turnstile first, entry and exit guiding indicators show "red no-entry" sign as standard. The guiding indicator will change to "Green arrow" for the free passing direction set with function buttons. If the the free passing direction is not set with function buttons, the 'red no-entry' sign remains. In the case of connecting a reader, coin unit, remote control, pushbutton and similar accessories to the turnstile, the guiding indicator shows the "Green arrow" while waiting in the locked position after the first pass is allowed. It will continue to show "Red no-entry" for the duration of passing.

When the turnstile switches to the "Emergency mode", the "Green arrow" is continuously blinks on the direction indicator showing that "continuous free pass" is allowed. At the same, if the buzzer on the control card is on, it gives audio warning. SW7 position does not change the working of LEDs in emergency mode.

### 4.5 Supply unit and grounding



*Figure 4.10 Supply unit*

The power supply of our turnstiles is shown in Figure 4.10. The phase (L), neutral (N) and grounding inputs of the supply unit are as shown in the figure. The supply unit is grounded by a cable connected to the chassis from the grounding part. Therefore, it is necessary to ground the turnstile frame, not the adapter. In this way, you can ground the turnstile frame first, and then the supply unit through the frame.

# 5

## ELECTRICAL CONNECTIONS

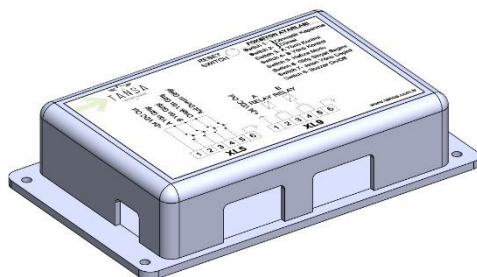
### 5.1 Control card and specifications

Open the electronic card box on the corner of the turnstile slowly by pressing lightly on the right and left sides to see the TEC-101 control card. When closing the cover of the card box, please pay attention to the electric cables. (Figure 5.1)

The circuit diagram of the control card in the turnstile is as in Figure 5.2. The software and functional equipment of the control card vary according to the turnstile model. All components on the control board consist of components to operate in industrial environment.

The LEDs on the electronic card show the operation status of the card in group 1 in Figure 5.1.1. The green LED flashes continuously. This indicates that the card processor is working properly. The other red LEDs are power LEDs. These LEDs show the presence of energy by flashing.

The label on the control card shows the mode of operation and version of the turnstile. Therefore, it should not be disassembled.



*Figure 5.1 Electronic card box*



Figure 5.1 shows the protective plastic box of the control board. On the membrane label located on the box, the connection diagrams of the input and output terminals and the functions of the switches are explained. There is a reset button on the card to restart the control card. There is a hole for access to the reset button, and you can reach the reset button by using a screwdriver to reset the device.

The TEC-101 turnstile control card has LEDs on all inputs and outputs. It can be monitored that the input or output related to these LEDs is working electronically.

The following figure shows the status and functions of the LEDs located on the control card.

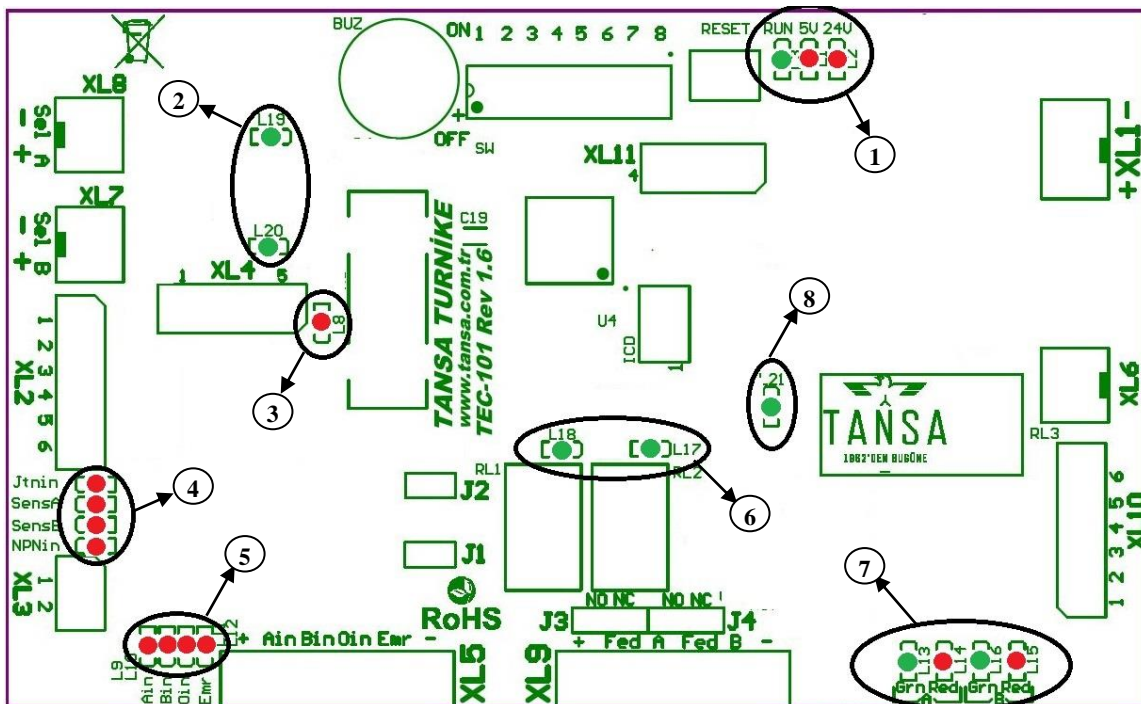


Figure 5.1.1 Control Card LED Layout

① These LEDs indicate the internal operating voltages of the turntable, that are + 5V and + 24V, and that the turnstile works. The function of the corresponding LED is written on it. During the breakdown, first it should be checked whether the + 24V LED is on, then the + 5V LED should be checked. If the + 5V LED is off the control card is defective and must be changed without any interference. The Run LED indicates that the processor of the control card is working. The Run LED flashes during normal operation, if it is continuously on or off, the control board is faulty.

## ELECTRICAL CONNECTIONS

---

- ② The LEDs in this block indicate whether the equipment is working by checking the solenoid outputs. The L19 and L20 LEDs turn green continuously when the solenoid is locked, and they must turn off in free mode or during passing.
- ③ The L8 LED in coin-operated turnstile models show whether the coin unit has an external +12V power supply connection.
- ④ The most important LEDs in this group are sensor LEDs. The operation of 2 direction sensors located on the mechanism is controlled by these LEDs. The SensA and SensB LEDs are on when the turnstile arm is in the middle position at idle, and they are all turned off when sensor disc passes through the sensors while the turntable arm rotates. If the sensor LEDs are all off or on during arm rotation, there may be a malfunction in the sensors or connection points.
- i** In very dusty environments, the inside of the sensors can be cleaned first with a fine brush and then with a damp cloth.
- ⑤ 4 LEDs (Ain, Bin, Oin, Emr) indicate whether the external inputs are working or not. The emergency input LED (Emr) must be permanently on unless there is an emergency. Ain, Bin, Oin will be on as long as there is a signal in the input. If these LEDs on 3 inputs are always on, it means that NC "normally closed" contact signal is connected to external inputs or that there is a connection error.
- ⑥ There is a dry corac relay output in the direction of pass after the arm rotation. The LEDs placed in front of these roles are turned on and off together with the 500mS relay after passing, so that it is understood that the relay is working and there is contact.
- ⑦ The LEDs in this group show the operation stop of the control LEDs at the entrance and exit of the turnstile. When the corresponding LED is on, it is understood that the guiding LED is working. Red / Green LEDs are used for direction A and direction B.
- ⑧ L21 LED is used in turnstiles with drop arm option. It turns on when the arm dropping motor is powered, and remains off at the other time.

## 5.2 TEC-101 Control card

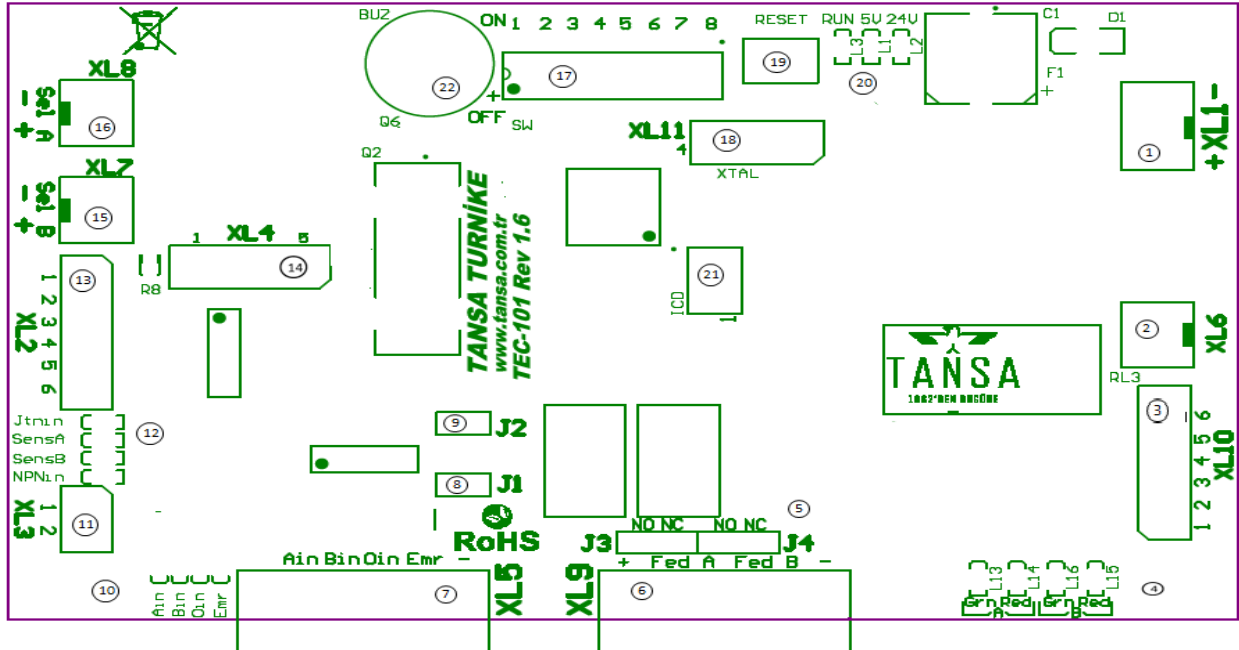


Figure 5.2 TEC101 Control Card

- |  |                                     |
|--|-------------------------------------|
| 1. Motherboard supply input (+24VDC)                                   | 12. Sensor inputs indicator LED     |
| 2. (Option) drop arm motor connection                                  | 13. Sensor Inputs                   |
| 3. A direction / B direction LED indicator connector                   | 14. Coin connection connector       |
| 4. Guiding indicators (Indicator LED)                                  | 15. B solenoid connection connector |
| 5. A direction / B direction pass information NO / NC selection jumper | 16. A solenoid connection connector |
| 6. A direction / B direction pass information relay output connector   | 17. On / off function switch        |
| 7. Control inputs connector  | 18. Serial connection connector     |
| 8. Emergency parallel connection jumper                                | 19. Reset switch                    |
| 9. Emergency active / passive jumper                                   | 20. Power LED indicator             |
| 10. Control inputs indicator LED                                       | 21. Programming socket              |
| 11. Option input   | 22. Buzzer                          |

### 5.3 Control card switch descriptions



Figure 5.3 Function switch

The functions of the on / off function switches (number 17 on the control card) seen in figure 5.3 above are as follows:



The switches are ON in Figure 5.3.

**Automatic shutdown time:** It is determined by the switch 1 and switch 2. It is the waiting time setting for the person to pass, corresponding to the "open" signal coming from the controller to the turnstile. If the person passes just after the open signal, the waiting time is cancelled and the turnstile is locked.

SWITCH 1	SWITCH 2	CLOSING TIME
ON	ON	20 seconds ( <b>factory settings</b> )
ON	OFF	10 seconds
OFF	ON	15 Seconds
OFF	OFF	5 Seconds

**Passing direction control:** It is determined by the switch 3 and switch 4. One or both of the desired directions of the turnstile designed for two-way controlled transition can be set to continuous free pass mode. The guiding led in the direction of free pass will be green.

SWITCH 3	PASSING DIRECTION
ON	A direction controlled ( <b>factory settings</b> )
OFF	A direction free

SWITCH 4	PASSING DIRECTION
ON	B direction controlled ( <b>factory settings</b> )
OFF	B direction free

**Memory mode selection:** It is determined by the switch 5. In standard turnstiles, after the entry signal is received, the input (Ain, Bin, Oin) is inactive and the incoming signals are not processed until passing is completed or the automatic closing is activated. With the memory mode, all entry signals (up to 200) are saved in the memory even during passing. With this mode, the turnstile can be operated in full capacity.

SWITCH-5	MEMORY MODE
ON	Memory mode on
OFF	Memory mode off ( <b>factory settings</b> )

**Continuous pass with entry signal:** It is determined by the switch 6. With this mode, if A direction, B direction and common input signals are received continuously without interruption, continuous passing is allowed. In some reader models, it is used when the relay trigger times are long and the reader signal is continuous in successive passes.

SWITCH-6	ENTRY SIGNAL
ON	Continuous passing
OFF	Single pass ( <b>factory settings</b> )

**Passing Direction and Guiding LED Operation Mode Selection in Coin Operated Mode:** With switch 7, both the coin-ejection direction is selected in coin operated mode, and the functioning of guiding LEDs can be changed as Green at idle or Red at idle. In coin operated turnstiles, it adjusts passing in direction A or B direction with coin.

SWITCH-7	PASSING DIRECTION / LED OPERATION TYPE
ON	Passing to direction A / Red at idle
OFF	Passing to direction B / Green at idle ( <b>factory settings</b> )

**Audio Warning On/Off:** It is determined by the switch 8. After the "open" command coming from the control system to the turnstile, it gives intermittent audio signal until passing or automatic closing. It is recommended to be used to make the users understand that they are allowed to pass.

SWITCH-8	AUDIO WARNING
ON	Warning on ( <b>factory settings</b> )
OFF	Warning off

## 5.4 Control card terminal descriptions (XL5)

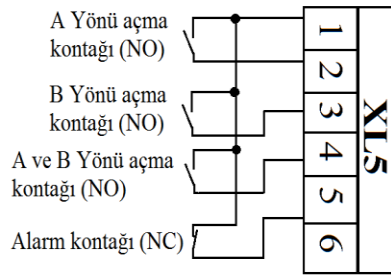
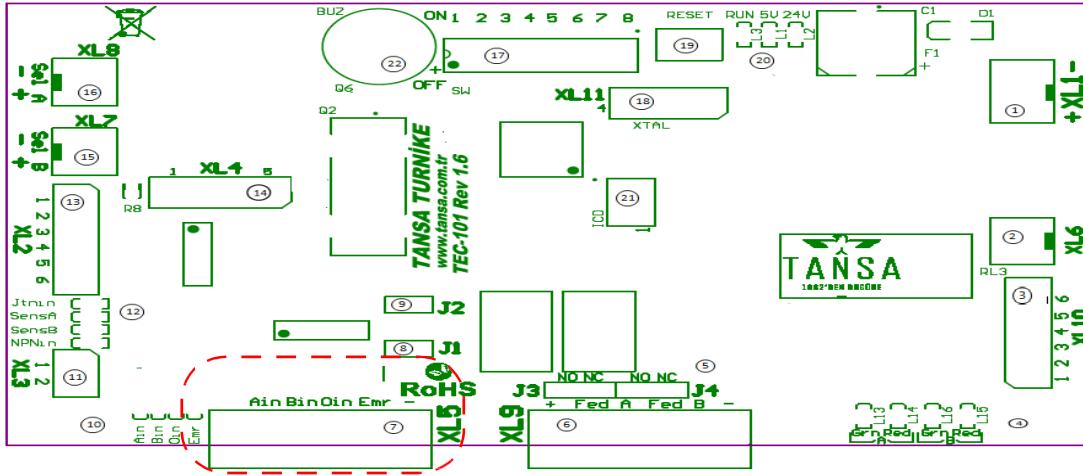


Figure 5.4 shows the connection diagram of the XL5 terminal on the TEC-101 Control Card.

Figure 5.4

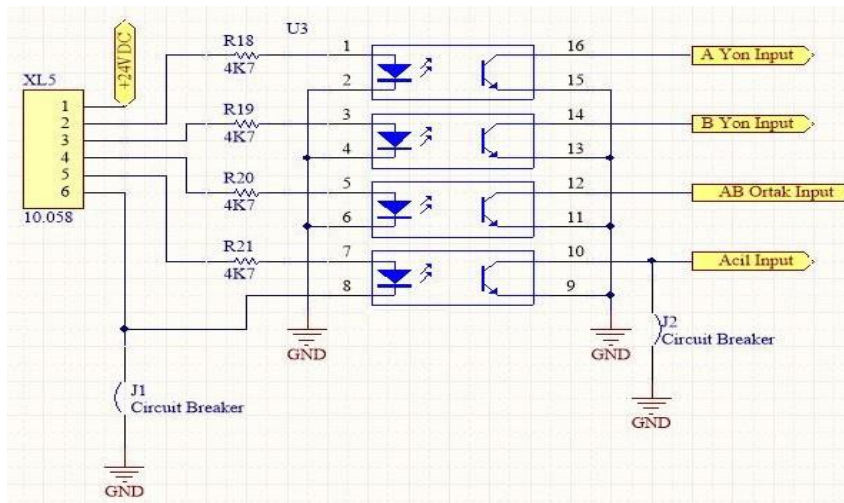


Figure 5.5 Circuit diagram of XL5 terminal.

## 5.4.1 External connection types

### 5.4.1.1 Triggering with dry contact

As shown in Figure 5.4, the pin 1 of the XL5 terminal is used as the common pole with +24VDC voltage. The pin 2 is used as opening to direction B, and the pin 3 is used as the opening to direction B inputs. In the normally open (NO) dry contact connection, +24VDC from the pin 1 is transferred to the pin 2 or the pin 3 via the relay contact or the pushbutton to allow passing.



*Normally open (NO) role / pushbutton contacts must be connected to control inputs, the normally closed (NC) contact should never be connected. If the normally closed (NC) contact is used instead of the normally open (NO) contact, there will be problems such as the turnstile delaying the passing permission. If it is used with this problem, the turnstile may be damaged as it will result in hitting the arms.*

**Normally closed (NC) contact connection is required for emergency. The J2 jumper (Fig. 5.5) is inserted when the turnstile is shipped from the factory. If the alarm contact is to be used, this short circuit jumper (J2) must be removed.**

### 5.4.1.2 Triggering with power input (PNP)

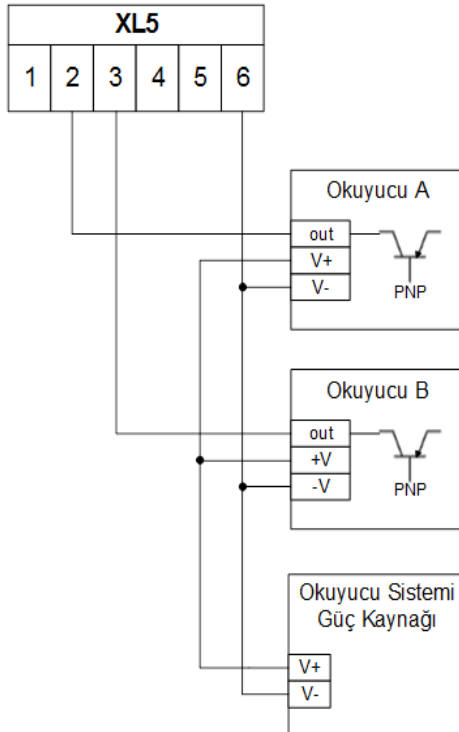


Figure 5.6

The opening to direction A input in the XL5 connector can also be controlled by the opening to direction B input and the emergency connection input + V (PNP). A voltage between +12 VDC and +24VDC can be used.

In the case of the use of a PNP output card reader, fingerprint reader, palm reader and similar hardware, this connection type can be used.

The pin 2 of terminal XL5 can be used to control passing to direction A, and the pin 3 can be used to control passing to direction B. The reader system's V- (GND) must be connected to pin 6 of the XL5 terminal. (Figure 5.6)



As the emergency input is the NC contact input, J2 pins are equipped with a short circuit jumper. If the emergency input is to be used, the J2 jumper must be removed and replaced with the emergency contact from the alarm panel. As long as the emergency input is active, the turnstile rotates freely in both directions. When an emergency signal is received in drop arm turnstiles, the arm in the middle position drops and allows passing. When the emergency state is passive again, the dropped arm must be lifted manually.

### 5.4.2 Alarm cable group turnstile connection

The emergency contact from the alarm panel (Normally closed - NC) must be connected to the first turnstile in a group of turnstiles. The other turnstiles must have a 2x0.50mm alarm cable connecting one with another in sequence. An emergency connection can be made with a single contact by grouping as many turnstiles as desired. The J2 jumpers on the control card of the turnstiles to have emergency connection must be removed.

Normally closed (NC) contact is required from the alarm panel in the following connection. As shown in the diagram, the J1 jumper is installed on the control board in the first turnstile with alarm cable, while it is not installed on other turnstiles. If installed, it must be definitely removed. (Figure 5.7)

Pin 6 (GND) of terminal XLS of turntables are connected to each other, and the pin 5 emergency inputs are connected to each other. Finally, the emergency contact from the alarm panel is connected to pin 1 (+ 24VDC) and pin 5 of terminal XL5.

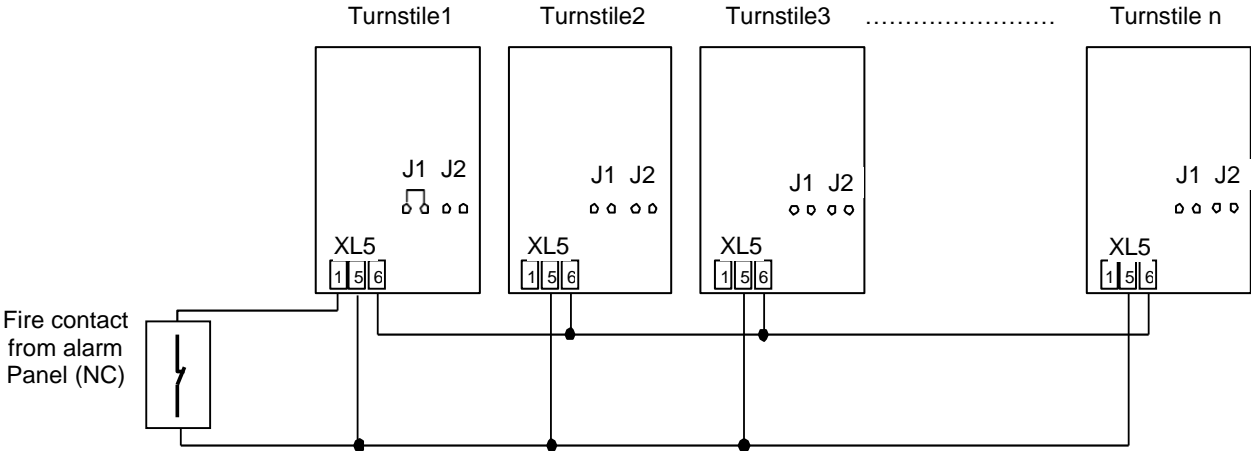


Figure 5.7 Alarm cable connection diagram



## 5.5 Control card terminal descriptions (XL9)

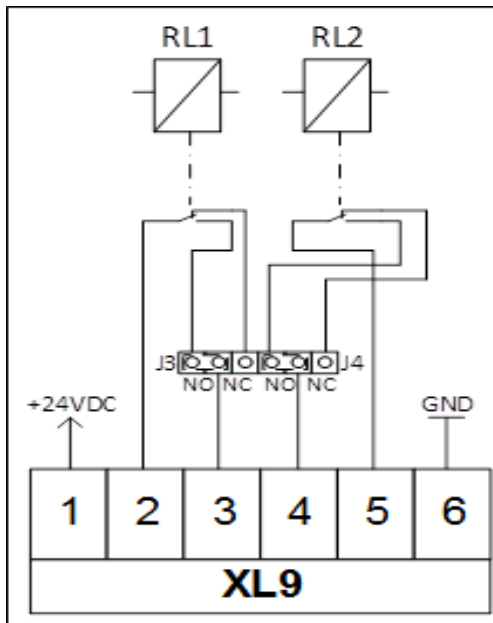
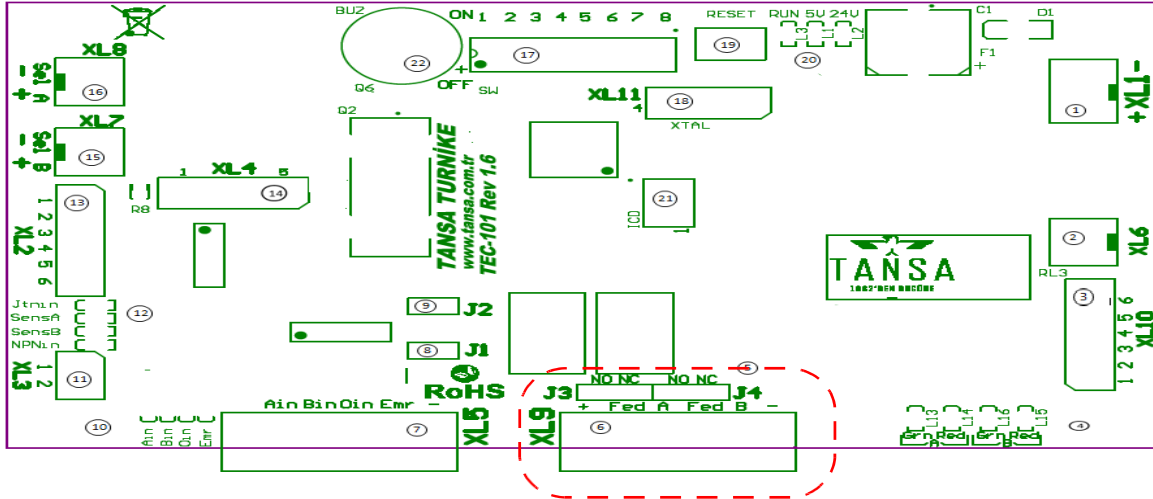


Figure 5.8

XL9 terminal has direction A and B pass relay contacts. (Figure 5.8) Relay contacts are normally open (NO) when the turnstile is at idle.

The pins 2 and 3 of terminal XL9 are connected to the relay RL1. The relay RL1 is active in passing to direction A. The pins 4 and 5 of terminal XL1 are connected to relay RL2. The relay RLw is active in passing to direction B.

The signal duration of the relays giving the pass information is 500mS. The corresponding relay pulls and releases at 500mS in each pass. The normally open (NO) and common (COM) poles of the RL1 and RL2 pass relays are removed in the factory as standard. If normally closed (NC) contact outputs are to be taken, J3 and J4 jumper should be removed from the

### 5.5.1 How to use the pass relays

There are 2 directional pass relays on the turnstile control card. Normally open (NO) poles of these relays are extended to terminal XL9. The pass information relay contact is available separately for A and B directions. At each rotation of the turnstile arm to direction A, the A direction pass contact 500mS is activated, and it becomes passive again. In the same way, every time the turnstile arm rotates to direction B, the B direction pass relay is activated, and it becomes passive again. A maximum of 500mA (30VDC) current can pass through the pass relay contacts, external relays should be used if more current is desired. Directional pass relays work independently of A/B direction opening and emergency inputs. They detect the rotation of the arm, even if the turnstile is in A/B direction, free or emergency mode, and send the pass information. Pass relays give a normally open (NO) contact output as standard, and if desired, jumpers J3 and J4 can be switched from normally open (NO) to normally closed (NC) to obtain contact information.

Directional pass relay can be used with the reader control system as well as for counter connection if desired.

### 5.5.2 Pass relays and counter connection

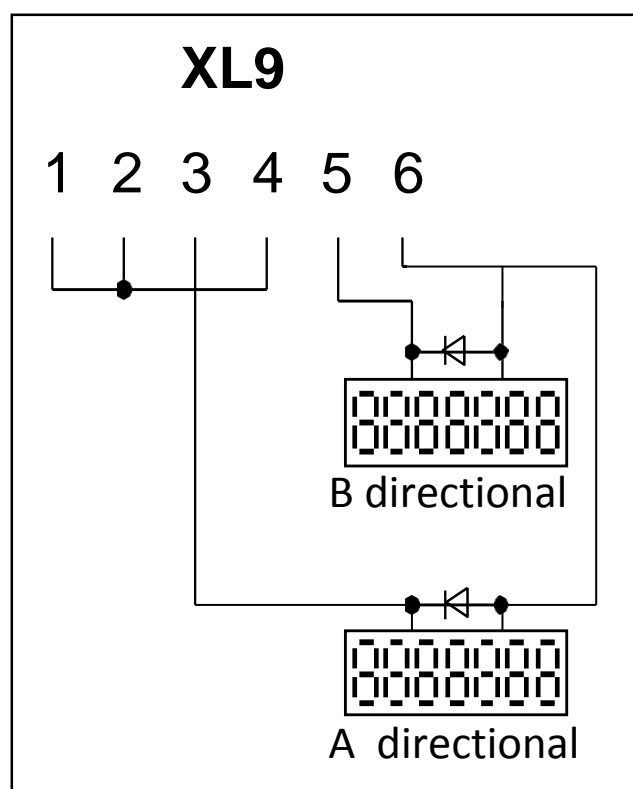


Figure 5.9

Figure 5.9 shows the mechanical counter connection using directional pass relays.

It is located on pin 1 of the XL9 terminal (+ 24VDC), this output can be used as the switching voltage to counters. For this purpose, pins 1, 2 and 4 of terminal XL9 must be short-circuited.

Pin 6 of the XL9 terminal (GND) is connected to the negative (-) poles of the counters. The diode (1N4007), which is connected in parallel to the poles of the counter, must be fitted in order to prevent interference. Note the direction of the diode in the connection, as the reverse connection may cause malfunction of the turnstile adapter.

Finally, pins 3 and 5 of terminal XL9 are connected to the plus (+) poles of the counters. Once the connection is completed, the corresponding counter will increase by one (1) value at each turn of the turnstile.

# 6

## PRODUCT USAGE INSTRUCTIONS

### 6.1 Safety and operating instructions

- Turnstile users should not open the turnstile. Maintenance and repair works must only be carried out by the Tansa Service Teams or by expert personnel. Unconscious interventions can lead to dangerous situations for turnstiles and for the user.
- The turnstiles must be protected from any kind of shock and vibration.
- Do not input any voltage other than the voltage values specified in the technical specifications of the turnstile.
- Do not exceed the relative humidity and operating temperature values specified in the technical specifications of the turnstile.
- Check all connections and make sure they are correct before supplying power to the turnstile.
- Do not use any equipment in the turnstile other than the hardware and parts supplied by the producer.
- Turn off the power supply in case of any electrical failure in turnstiles. Directly contact the manufacturer without any intervention.
- Make sure that the power is cut off during maintenance and cleaning of the turnstiles.
- The interior of the turnstile should not take any water.
- Do not use the turnstile in high magnetic fields.
- The turnstile cannot be stored or operated in humid environments.
- Do not continue to use your turnstile if it is damaged or faulty. Contact and inform the producer's technical service without delay.
- Do not allow children or unauthorized persons to play with or tamper the turnstile.

## 6.2 Maintenance Instructions



*Take care not to have the turnstile switched on when performing the maintenance.*

- Turnstile arms / wings should be cleaned regularly. Turnstile case and body should be cleaned regularly.
- Acidic or basic chemicals should never be used on the sheet metal surface of the turnstile. Stainless maintenance spray should be used for all sheet metal surfaces. If you do not have any, please contact the producer company for supply.
- The mechanism should be cleaned and lubricated periodically every six months. Molykote grease should be used for the lubrication of the mechanism.
- The shock absorber and brake settings of the mechanism should be checked and adjusted during maintenance.
- The inside of the turnstile should be wiped with dry cloth regularly and not exposed to dust.



# FAULT CONDITION

## 7.1 Troubleshooting

If you think there is a problem with your turnstile, check the chart below and review the solutions. If you cannot resolve the problems, please contact Tansa Technical Service for technical assistance.

>> The turnstile arms do not lock, guiding LEDs are not working and the turnstile does not receive commands even though there is power.

**Reason:** 220 VAC energy may not be enough. The power cord to the motherboard may have been displaced. The supply unit may be defective.

**Solution:** 220 VAC energy from the supply unit should be checked with energy meter. Internal and external power cables should be checked manually and visually.

>> There is energy in the turnstile, the guiding LEDs are on, but the arms run idle. Solenoids do not lock.

**Reason:** The cables of the locking solenoids may have been displaced. The control card may be defective. The solenoid locking pins may be jammed.

**Solution:** Check the cables between the control card and the solenoid. Measure voltage values.

>> Guiding LED lights are on 'green arrow' position and the pass signal sounds, but the turnstile arms do not allow to pass.

**Reason:** Solenoids may be defective. Solenoid springs may have been deformed and may not be able to pull the tabs. The control card may be defective.

**Solution:** If the solenoid is defective, it must be replaced. The solenoids must be cleaned with contact spray. If the springs are deformed, they should be replaced. If the control card is defective, it should be replaced.

>> The turnstile allows to pass but does not lock after passing. It locks automatically after several passes.

**Reason:** The directional sensors may be defective. There may be loose contact in the connection of the directional sensors. The control card may be defective.

**Solution:** If the sensors are defective, they must be replaced. Check the cable terminals manually and visually. If they are defective, they should be replaced. If the control card is defective, it should be replaced.

>> After the pass, the arms stay crossed before coming to the center, or they hit and stop in an audible manner.

**Reason:** The shock absorber may be out of adjustment. The shock absorber may be defective. The shock absorber bearing may be defective.

**Solution:** The shock absorber should be adjusted as described in the user in the manual. If the shock absorber is defective, it should be replaced. If the bearing is defective, it should be replaced.

>> The arm of the drop-arm turnstile does not drop even in emergency contact.

**Reason:** The motor may be defective. The directional sensors may be defective. The drop pin may be jammed.

**Solution:** If the motor is defective, it must be replaced. If the sensors are defective, they should be replaced. The drop pin should be cleaned and lubricated.

>> While passing, the arms remain stuck, do not turn, or hardly turn and jam.

**Reason:** The ratchet spring may be damaged. A cable or an external element may be stuck in the mechanism. Movement springs may be not working.

**Solution:** If the ratchet spring is defective, it should be replaced. The turnstile should be turned off and not turned on again. Contact the authorized service. If the springs are deformed, they should be replaced.

>> In the drop arm turnstile, the arm cannot be lifted after it drops, it keeps dropping.

**Reason:** The arm drop pin may not fit into the socket. The arm drop pin may be jammed or clogged.

**Solution:** The arm drop pin should be cleaned with contact spray and similar materials. The machine should be lubricated with oil to make the pin easy to function. If the problem is not solved, it should be replaced.

>> "Passed" or "arm turned" information is not received after passing

**Reason:** Connections may be broken or incorrect. The 'XL9 terminal' of the control card may be defective.

**Solution:** The connections should be checked manually and visually. If the control card is defective, it should be replaced.

>> The turnstile allows a continuous pass to one direction.

**Reason:** It may be running in one-way free mode. The solenoid cable or spring may be displaced.

**Solution:** The "3rd" and "4th" dip switch positions of the control card should be checked. If there is a displaced spring or cable, it should be replaced. If it doesn't work, it should be replaced.

>> The turnstile works properly with all its functions, but the guiding LEDs do not turn on.

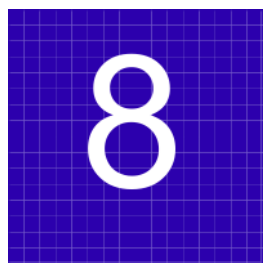
**Reason:** LED cards or LED cables may be defective. The motherboard may be defective.

**Solution:** If the LED card is defective, it should be replaced. If the LED cable is defective, it should be replaced. If the card is defective, it should be replaced.

## **TANSA TECHNICAL SERVICE CONTACT**

**Phone** +90 (216) 561 96 71 - 72 -73

**E-mail:** destek@tansa.com.tr



# WARRANTIES

## 8.1 Warranty Conditions

- The Warranty Period starts from the date of production of the product. The turnstile is guaranteed for 2 years against production and installation errors. Users who wish to benefit from the warranty are obliged to declare the serial number on the product or the invoice information to TANSA.
- During 2 years covered by the warranty period, TANSA shall provide on-site service and spare parts supply free of charge.
- The producer warranty period given by TANSA is 2 years. This period can optionally be extended by up to 5 years with the "Extended Supplementary Warranty Service" provided by TANSA during product purchase.
- After the expiry of the warranty period, the prices for the service and spare part supply services for the turnstile shall be charged to the user by TANSA.
- The warranty of the parts replaced during the warranty period shall end as of the warranty end date of the turnstile.
- A 6-month warranty is given for parts that are replaced out of the warranty period.
- For products that have failed within the warranty period and been taken to the factory for repair, the period of time spent for the repair shall be added to the warranty period of the product.
- The repair period of the defective product is maximum 30 working days.
- If the product cannot be repaired within the 30-day maximum repair period, a product that can serve as an equivalent with the same specifications shall be allocated to the user by TANSA.



*We recommend you to follow the suggestions below.*

- It is the responsibility of TANSA to share the services provided by TANSA Turnstile Technical Service Teams with the user and to exchange information, and it is the responsibility of the end user to follow-up the fulfillment of the desired obligations by the provided service.
- It should be confirmed by the end user that the personnel coming for service are the employees of TANSA and the documents submitted are service forms with TANSA logo.
- The user is responsible for keeping and saving the product warranty, invoice or serial number information. When the service teams want to see these documents, at least one of them should be declared.
- The services provided by TANSA are recorded on service forms and shared with the user. This document about the operations carried out shall be signed by both the TANSA personnel and the user.

## 8.2 Out of Warranty Conditions

- In case of failure to declare any warranty certificate, serial number label or invoice of the product, and if these documents are unreadable and damaged, it is deemed to be out of warranty.
- All accessories, hardware and modifications out of TANSA's information and approval and any defects or problems caused by these will be out of warranty and result in the termination of the warranty of the product.
- Any intervention to failure, part replacement, etc. by an unauthorized person or persons except the TANSA service teams will result in the termination of the warranty period of the product.
- Failures resulting from the supply of power from the turnstile control card or the turnstile power unit to any equipment such as the card reader, validator, coin unit, etc. will result in service to be out of warranty.
- Any problems caused by the inappropriate and incorrect uses stated below will result in service to be out of warranty.
  - Intentional and/or Malicious Use,
  - Natural disasters (fire, flood, earthquake etc.),
  - Unauthorized repair, maintenance and intervention,
  - Non-compliance with product usage instructions,
  - Physical damage caused by impact, pressure or accident,
  - Damages that occur during transportation by shipping, cargo, etc.
  - Installation-based problems such as voltage fluctuations, poor grounding, short circuit, etc.

## 8.3 Warranty Certificate

Take care to keep the warranty certificate provided by TANSA with your turnstile without any damage.

**The following are included in the warranty certificate;**

- *Model of the turnstile,*
- *Serial number of the turnstile,*
- *Class of the turnstile,*
- *Production date of the turnstile.*

In addition to this information, the product quantity, the end user and the vendor information should be included in the warranty certificate.

If you have not received your Warranty Document, please contact the vendor company or the producer Tansa without delay.

Please check that your warranty certificate is prepared in full when receiving the product.

# 9

## QUALITY

### 9.1 Management system certificate and attachment

*Yönetim Sistem Belgesi*

**Bu Sertifika**

**TANSA GÜVENLİK SİSTEMLERİ VE SAAT SAN. TİC. A.Ş.**

firmasının **ISO 9001:2008** şartlarına uygun bir Kalite Yönetim Sistemine sahip olduğunu onaylar.

Belge No. : **AJA 15/0920** Belgelendirme Tarihi : **15/07/2015**

Geçerlilik Tarihi : **02/07/2018** Yeniden Belgelendirme Tarihi : -

*Mehmet Selçuk*  
Genel Müdür

Bu sertifikasının geçerliliği, firmasının AJA prosedürlerine uygunluğu ve yılda en az bir kez yapılacak dış denetimlerin başarılı geçmesiyle bağlıdır. Belgelerin Ekstendi, belgelendirme kapsamına ve veri değiştirilmezler. Bu belge AJA'ya aittir, temyizliğine gowi verilemezdir. AJA 5000 Belgelendirme Ltd. Şti. Ankara Yolu, Pendik, Kavayi Dumanakapı Plaza Kat:2 No:18-19 Pendik/İSTANBUL. Tel:0 216 598 30 00 (Faks) Fax:0 216 598 30 04 www.ajaturk.com

*Yönetim Sistem Belgesi Eki*

**BELGE KAPSAMI**

**Güvenlik Sistemleri ( Geçiş Kontrol Sistemleri, Turnikeler) Üretimi ve Satışı**

Kuruluş Adı : **TANSA GÜVENLİK SİSTEMLERİ VE SAAT SAN. TİC. A.Ş.**

Kuruluş Adresi : **Eyüp Sultan Mahallesi, Hoca Nasrettin Caddesi, No:10 Sancaktepe /İSTANBUL**

Standart : **ISO 9001:2008**

EAC : **17**

Belgelendirme Tarihi : **15/07/2015**

Geçerlilik Tarihi : **02/07/2018**

Belge Numarası : **AJA 15/0920**

*Mehmet Selçuk*  
Genel Müdür

Bu sertifikasının geçerliliği, firmasının AJA prosedürlerine uygunluğu ve yılda en az bir kez yapılacak dış denetimlerin başarılı geçmesiyle bağlıdır. Bu belge AJA'ya aittir, temyizliğinde gowi verilemezdir. AJA 9000 Belgelendirme Ltd. Şti. Ankara Yolu, Pendik, Kavayi Dumanakapı Plaza Kat:2 No:18-19 Pendik/İSTANBUL. Tel:0 216 598 30 00 (Faks) Fax:0 216 598 30 04 www.ajaturk.com

# 9.2 TSE Certificate and CE Certificate



CERTIFICATE No. : 0864/IN-IST-09  
ISO950-0622/MKE/AKC

**EC-ATTESTATION CERTIFICATE  
OF MACHINE SAFETY**

**Date of Issue** : 17.11.2009

**Client (Name & Address)** : TANSa GÜVENLİK SİSTEMLERİ VE SAAT SAN. TİC. A.Ş.  
Rami Kışla Cd. Emiñtaş Rami İş Mrk. No. 238-245  
34050 Rami - İSTANBUL / TURKEY

**Manufacturer (Name & Address)** : TANSa GÜVENLİK SİSTEMLERİ VE SAAT SAN. TİC. A.Ş.  
Rami Kışla Cd. Emiñtaş Rami İş Mrk. No. 238-245  
34050 Rami - İSTANBUL / TURKEY

**Description of Product(s)** : Half Height Turnstiles, Full Height Turnstiles, Swinggates, Speedgates

**Model(s)** : LTT 303, 303A, 303E, 313, 323, 343, LTF 103, 104, 113, 114, 413, 414, 513, 514, SGWMC, SG312, SGWS, SGWE, SGWL

**Assessment Performed** : Conformity to Annex 1 Section 1, the Essential Health and Safety Requirements of 98/37/EC Machinery Directive, 2006/95/EC Low Voltage Directive.

**Standard(s)** : EN ISO 12100-1:2003 ; EN ISO 12100-2:2003 ; EN 60204-1:2006 ; EN ISO 14121-1:2007

The above products which had been manufactured by TANSa GÜVENLİK SİSTEMLERİ VE SAAT SAN. TİC. A.Ş. in conformity with the technical files are reviewed and found to be ACCEPTABLE according to the 98/37/EC Machinery Directive Annex 1 Section 1, 2006/95/EC Low Voltage Directive and harmonized standards (EN ISO 12100-1; EN ISO 12100-2; EN 60204-1; EN ISO 14121-1)

The CE mark as shown below can be used under the responsibility of the manufacturer, after completion of an EC Declaration of Conformity and compliance with all relevant EC Directives.



This Certificate is issued by SGS Supervise Gözetme Etüd Kontrol Servisleri A.Ş. under its General Conditions for System, Product & Service Certification. The issuance of this Certificate does not exonerate buyers or sellers from exercising all their rights and obligations at their facilities under the Contract of Sale. Situations to the contrary are not binding on the SGS Supervise Gözetme Etüd Kontrol Servisleri A.Ş.

Issued in İstanbul  
On 17<sup>th</sup> November, 2009




**SGS Supervise Gözetme Etüd Kontrol Servisleri A.Ş.**  
Abide-i Hürriyet Cad. Geçiş Sokak  
NO:10 K:1-2-3-4 34381 Şişli İstanbul-TURKEY  
T: 90 212 2864000 (Tlx)  
F: 90 212 2964782-83  
E: sgs\_turkey@sgs.com

S-IND-F-32/ Rev1

This document is issued by the Company under its General Conditions of Service printed separately. Attention is drawn to the inclusion of all the relevant conditions and justifications under the said document.

Any holder of this document is advised that the information contained therein reflects the Company's findings at the time of the information and is not a guarantee of the accuracy of the information. The Company's sole responsibility is to its Client and this document does not constitute a representation from the Company or its agents and shall not be used for any other purpose. Any representation otherwise, without the written consent of the Company, shall be deemed null and void. The information is provided to the Client under the terms of the contract.

**SGSPAPER**  **09554715**



**TÜRK STANDARLARI ENSTİTÜSÜ**  
**KRİTERE UYGUNLUK BELGESİ**  
**TURKISH STANDARDS INSTITUTION**  
**CERTIFICATE OF CONFORMANCE TO CRITERIA**

Markanın Tanımı	Description of the Mark
<b>TSEK</b>	<b>TSEK</b> veya <b>Т-0342</b>
<b>BELGE NUMARASI</b> REFERENCE NUMBER OF LICENCE	011820-TSEK-01/01
<b>BELGENİN İLK VERİLİŞ TARİHİ</b> DATE OF FIRST ISSUE OF LICENCE	27.08.2012
<b>BELGENİN SON GEÇERLİLİK TARİHİ</b> LICENCE VALID UNTIL	28.12.2017
<b>BELGE SAHİBİ KURULUŞUN ADI</b> NAME OF THE LICENCE HOLDER	TANSa GÜVENLİK SİSTEM VE SAAT SAN.TİC.AŞ.
<b>BELGE SAHİBİ KURULUŞUN ADRESİ</b> ADDRESS OF THE LICENCE HOLDER	EYÜP SULTAN Mh HOCA NASREDDİN Cd. NO:10 SANCARTEPE İSTANBUL
<b>ÖRETİM YERİ ADI</b> NAME OF THE MANUFACTURING PLACE	TANSa GÜVENLİK SİSTEMLERİ VE SAAT SANAYİ TİC. A.Ş.
<b>ÖRETİM YERİ ADRESİ</b> ADDRESS OF THE MANUFACTURING PLACE	EYÜP SULTAN MAH. HOCA NASREDDİN CAD. NO : 10 SANCARTEPE / İSTANBUL İSTANBUL
<b>TESCİLLİ TİCARİ MARKASI</b> REGISTERED TRADE MARK	"Tansa" Şekli
<b>İLGİLİ BELGELENDİRME KRİTERİ</b> RELATED TURKISH STANDARD	TSE K 1 / Elektrikli güvenlik baryerleri / 09.12.2014
<b>BELGE KAPSAMI</b> SCOPE OF LICENCE	*BEL TURKELERİ: LTT 303, LTT 303 D, LTT 313, LTT 313 D, LTT 303 A, LTT 303 A D, LTT 323, LTT 323 D, LTT 303 E, LTT 303 S, LTT 303 SA *SÖY TURKELERİ: LTF 113 TE, LTF 113 TP, LTF 113 TE D, LTF 113 TP D, LTF 114 TE, LTF 114 TP, LTF 114 TE D, LTF 114 TP D, LTF 413 TE, LTF 413 TP, LTF 413 TE D, LTF 413 TP D, LTF 414 TE, LTF 414 TP, LTF 414 TE D, LTF 414 TP D, LTF 113 S TE, LTF 113 S TP, LTF 113 S TE D, LTF 113 S TP D, LTF 114 S TE, LTF 114 S TP, LTF 114 S TE D, LTF 114 S TP D, LTF 413 S TE, LTF 413 S TP, LTF 413 S TE D, LTF 413 S TP D, LTF 414 S TE, LTF 414 S TP, LTF 414 S TE D, LTF 414 S TP D *SIVRI GATE: SG 312, SG 142, SG WMC *HIZLI GEÇİŞ TURKELERİ: LTOP 101, LTOP 201, LTOP 301, LTOP 401, LTOP 1511, LTOP 251, LTOP 351, LTOP 111





**TSE İSTANBUL BELGELENDİRME MÜDÜRÜ**

\*Bu belge, belgelendirilen ürünün, üretim yerinin (Etiler) ile ilgili olarak belgelendirme kapsamındaki diğer ürünler için geçerlidir.  
\*TSE İSTANBUL BELGELENDİRME MÜDÜRÜ, TSE'nin Genel Şartları'na göre belgelendirme hizmetleri sunar. TSE'nin belgelendirme hizmetleri için ayrıntılı bilgi için TSE'nin web sitesine gidilebilir.  
\*TSE'nin belgelendirme hizmetleri hakkında daha fazla bilgi için TSE'nin Genel Şartları'na bakılabilir. TSE'nin belgelendirme hizmetleri için ayrıntılı bilgi için TSE'nin web sitesine gidilebilir.  
\*TSE'nin belgelendirme hizmetleri hakkında daha fazla bilgi için TSE'nin Genel Şartları'na bakılabilir. TSE'nin belgelendirme hizmetleri için ayrıntılı bilgi için TSE'nin web sitesine gidilebilir.

https://www.tse.org.tr/portal/egitim/egitim.aspx?tip=egitim ve belgelendirme belgelendirme ve belgelendirme

